

# OFT-07W01

7" Open Frame Tablet

## Quick Reference Guide

2<sup>nd</sup> Ed –16 July 2018

### Copyright Notice

Copyright © 2018 ALL RIGHTS RESERVED.



## **Federal Communication Commission Interference Statement**

**THIS DEVICE COMPLIES WITH PART 15 OF THE FCC RULES. OPERATION IS SUBJECT TO THE FOLLOWING TWO CONDITIONS: (1) THIS DEVICE MAY NOT CAUSE HARMFUL INTERFERENCE AND (2) THIS DEVICE MUST ACCEPT ANY INTERFERENCE RECEIVED, INCLUDING INTERFERENCE THAT MAY CAUSE UNDESIRE OPERATION.**

**Note: This equipment has been tested and found to comply with the limits for a Class A digital device, pursuant to Part 15 of FCC Rules. These limits are designed to provide reasonable protection against harmful interference in a residential installation. This equipment generates, uses and can radiate radio frequency energy and, if not installed and used in accordance with the instruction, may cause harmful interference to radio communications. However, there is no guarantee that interference will not occur in a particular installation. If this equipment does cause harmful interference to radio or television reception, which can be determined by turning the equipment off and on, the user is encouraged to try to correct the interference by one or more of the following measures:**

- **Reorient or relocate the receiving antenna.**
- **Increase the separation between the equipment and receiver.**
- **Connect the equipment into an outlet on a circuit different from that to which the receiver is connected.**
- **Consult the dealer or an experienced radio/TV technician for help.**

**Notice:**

- (1) A Unshielded-type power cord is required in order to meet FCC emission limits and also to prevent interference to the nearby radio and television reception. It is essential that only the supplied power cord be used.**
- (2) Use only shielded cables to connect I/O devices to this equipment.**
- (3) Changes or modifications not expressly approved by the party responsible for compliance could void the user's authority to operate the equipment.**

## **FCC RF Radiation Exposure Statement**

**This Wireless LAN radio device has been evaluated under FCC Bulletin OET 65 and found compliant to the requirements as set forth in CFR 47 Sections 2.1091, 2.1093, and 15.247 (b) (4) addressing RF Exposure from radio frequency devices. The radiated output power of this Wireless LAN device is far below the FCC radio frequency exposure limits. Nevertheless, this device shall be used in such a manner that the potential for human contact during normal operation is minimized. When nearby persons has to be kept to ensure RF exposure compliance, in order to comply with RF exposure limits established in the ANSI C95.1 standards, the distance between the antennas and the user should not be less than 20 cm.**

**WARNING**

**“CAUTION – Use suitable mounting apparatus to avoid risk of injury.”**

**“CAUTION – This is a Class A product. In a domestic environment this product may cause radio interference in which case the user may be required to take adequate measures”**

**“CAUTION –Risk of explosion if battery is replaced by an incorrect type. Dispose of used batteries according to the instructions.”**

**“CAUTION - Use a power cord that matches the voltage of the power outlet, which has been approved and complies with the safety standard of your particular country.”**

**“WARNING – To avoid risk of electric shock, this equipment must only be connected to a supply mains with protective earth.”**

WiFi information :

<b>Product Description</b>	<b>IEEE 802.11 b/g/n Wireless LAN and Bluetooth Combo LGA Module</b>
<b>WLAN Standard</b>	<b>IEEE 802.11b/g/n, Wi-Fi compliant</b>
<b>Bluetooth Standard</b>	<b>Bluetooth 2.1+Enhanced Data Rate (EDR) / BT4.0</b>
<b>Major Chipset</b>	<b>Realtek RTL8723BS</b>
<b>WiFi PID/VID</b>	<b>B723 / 024C</b>
<b>Antenna Type</b>	<b>PIFA</b>
<b>Operating Conditions</b>	
<b>Temperature</b>	<b>Operating: 0~70 °C ; Storage: -20~85 °C</b>
<b>Electrical Specifications</b>	
<b>Frequency Range</b>	<b>WLAN: 2.4 GHz Band 2.412-2.472 GHz Bluetooth: 2400~2483.5MHz</b>
<b>Number of Channels</b>	<b>802.11b: USA, Canada and Taiwan : 1 ~ 11 Most European Countries : 1 ~ 13 Japan : 1 ~ 13 802.11g: USA and Canada : 1 ~ 11 Most European Countries : 1 ~ 13 802.11n: USA and Canada : 1 ~ 11 Most European Countries : 1 ~ 13</b>
<b>Modulation</b>	<b>WLAN: DSSS, OFDM, BPSK(9/6Mbps), QPSK(18/12Mbps), DBPSK(1Mbps), DQPSK(2Mbps), CCK(11/5.5Mbps), 16-QAM(36/24Mbps), 64-QAM (72.2/54/48Mbps) Bluetooth: GFSK (1Mbps), Π/4DQPSK (2Mbps) and 8DPSK (3Mbps)</b>

# Content

<b>1. Getting Started</b>	<b>7</b>
1.1 Safety Precautions	7
1.2 Packing List	7
1.3 System Specifications	8
1.4 System Overview	10
1.4.1 Top View	10
1.4.2 Bottom View	10
1.5 System Dimensions	11
1.5.1 Front and Rear side	11
1.5.2 Installing Extend Brackets	12
1.5.3 Front and Rear side (With Extend Bracket)	13
1.6 Flush Mounting Concept	14
1.7 Panel Mounting	15
1.8 Wall Mounting Concept	22
<b>2. Hardware Configuration</b>	<b>23</b>
2.1 Architecture Overview—Block Diagram	24
2.2 BCX12 Overviews	25
2.3 BCX12 Connector list	26
2.4 BCX12 Connectors settings	28
2.4.1 Touch button board connector (JTJB)	28
2.4.2 General purpose I/O connector (JDIO)	28
2.4.3 RS-232 connector (J232)	29
2.4.4 RS-485 connector (J485)	29
2.4.5 USB connector (JCAM)	30
2.4.6 USB connector (JUSB3)	30
2.4.7 SPEAKER_L (JAMP_L)	31
2.4.8 SPEAKER_R (JAMP_R)	31
2.4.9 A-MIC connector (JAMIC)	32
2.4.10 I2C connector (JSEN)	32
2.4.11 Touch connector (JTP)	33
2.4.12 DC Power-in connector (JDCIN3)	33
2.5 FCC	34
2.6 Android Rotate Setting	35

# 1. Getting Started

## 1.1 Safety Precautions

### Warning!



Always completely disconnect the power cord from your chassis whenever you work with the hardware. Do not make connections while the power is on. Sensitive electronic components can be damaged by sudden power surges. Only experienced electronics personnel should open the PC chassis.

### Caution!



Always ground yourself to remove any static charge before touching the CPU card. Modern electronic devices are very sensitive to static electric charges. As a safety precaution, use a grounding wrist strap at all times. Place all electronic components in a static-dissipative surface or static-shielded bag when they are not in the chassis.

## 1.2 Packing List

- 1 x OFT-07W01 Open Frame Tablet



---

If any of the above items is damaged or missing, contact your retailer.

---

## 1.3 System Specifications

Board Specification	
<b>Processor</b>	<ul style="list-style-type: none"> <li>Intel Atom Z3735F</li> </ul>
<b>System Memory</b>	<ul style="list-style-type: none"> <li>2GB DDR3L RAM</li> </ul>
<b>Storage</b>	<ul style="list-style-type: none"> <li>8GB or 32GB eMMC</li> </ul>
RF	
<b>WIFI</b>	<ul style="list-style-type: none"> <li>WIFI 802.11 b/g/n/</li> </ul>
System Specification	
Internal I/O	
<b>MIO</b>	<ul style="list-style-type: none"> <li>1 x RS232 (TX/RX) / RS485 header</li> <li>1 x 16 bit GPIO header</li> <li>1 x USB connector</li> <li>1 x eDP &amp; Dual channel 24bit LVDS</li> <li>1 x backlight control &amp; power</li> <li>2 x speaker header (1.2W stereo)</li> <li>1 x A-MIC header</li> <li>1 x Touch Button connector header</li> <li>1 x DC input 4pin header</li> </ul>
External I/O	
<b>USB</b>	<ul style="list-style-type: none"> <li>2 x USB 2.0</li> <li>1 x micro USB Client (Android only)</li> </ul>
<b>LAN</b>	<ul style="list-style-type: none"> <li>1 x 10/100 Ethernet</li> </ul>
<b>Display</b>	<ul style="list-style-type: none"> <li>1 x HDMI</li> </ul>
<b>Audio</b>	<ul style="list-style-type: none"> <li>1 x Head phone jack</li> </ul>
<b>SD</b>	<ul style="list-style-type: none"> <li>1 x Micro SD slot</li> </ul>
<b>Power-in</b>	<ul style="list-style-type: none"> <li>1 x DC jack</li> </ul>
Mechanical & Environmental	
<b>Power Requirement</b>	<ul style="list-style-type: none"> <li>12V~24V DC input</li> </ul>
<b>Power Type</b>	<ul style="list-style-type: none"> <li>DC Jack</li> <li>DC input 4pin header</li> </ul>
<b>Operating Temp.</b>	<ul style="list-style-type: none"> <li>0°C ~ 40°C</li> </ul>
<b>Storage Temp.</b>	<ul style="list-style-type: none"> <li>-20°C ~ 60°C</li> </ul>
<b>Operating Humidity</b>	<ul style="list-style-type: none"> <li>0% ~ 90% Relative Humidity, Non-condensing</li> </ul>



LCD Characters	
Panel	
Resolution	1280 x 800
Luminance	220
View Angle (H+-/V+-)	80°/80°
Touch	
Touch	PCAP
Surface hardness	6H



**Note:** Specifications are subject to change without notice.

## 1.4 System Overview

### 1.4.1 Top View

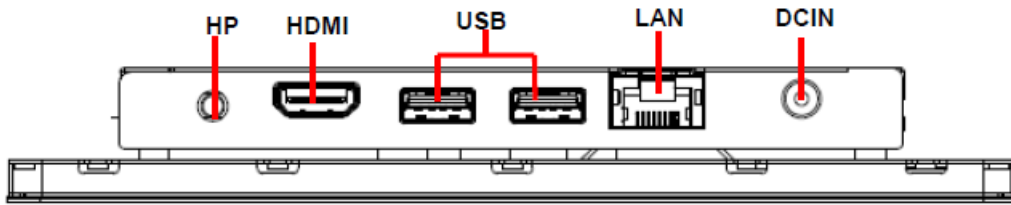

### 1.4.2 Bottom View

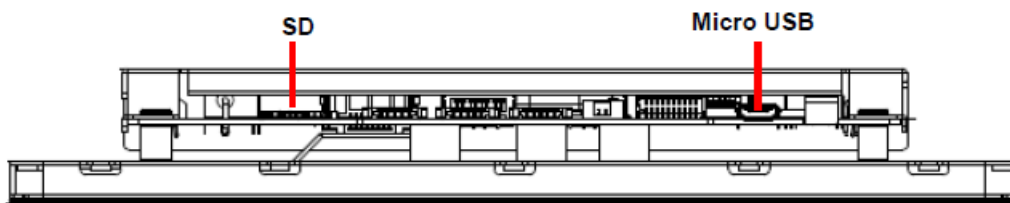

### Connectors

Label	Function	Note
HP	Audio line-out connector	
HDMI	HDMI connector	
USB	2 x USB 2.0 connector	
LAN	RJ-45 Ethernet	
DCIN	DC power-in connector	
SD	Micro SD card slot	
Micro USB	Micro USB connector	

## 1.5 System Dimensions

### 1.5.1 Front and Rear side

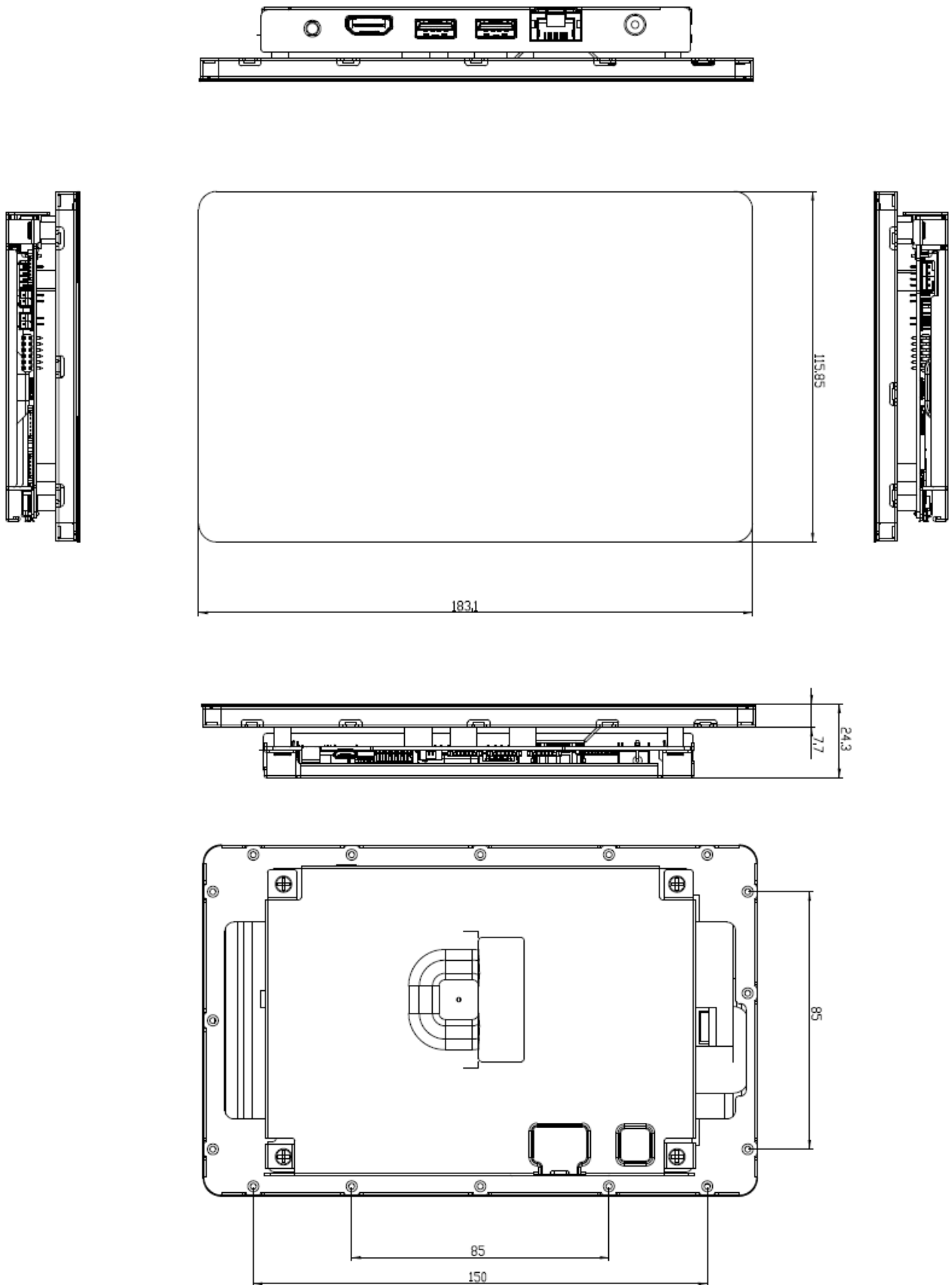

(Unit: mm)

## 1.5.2 Installing Extend Brackets

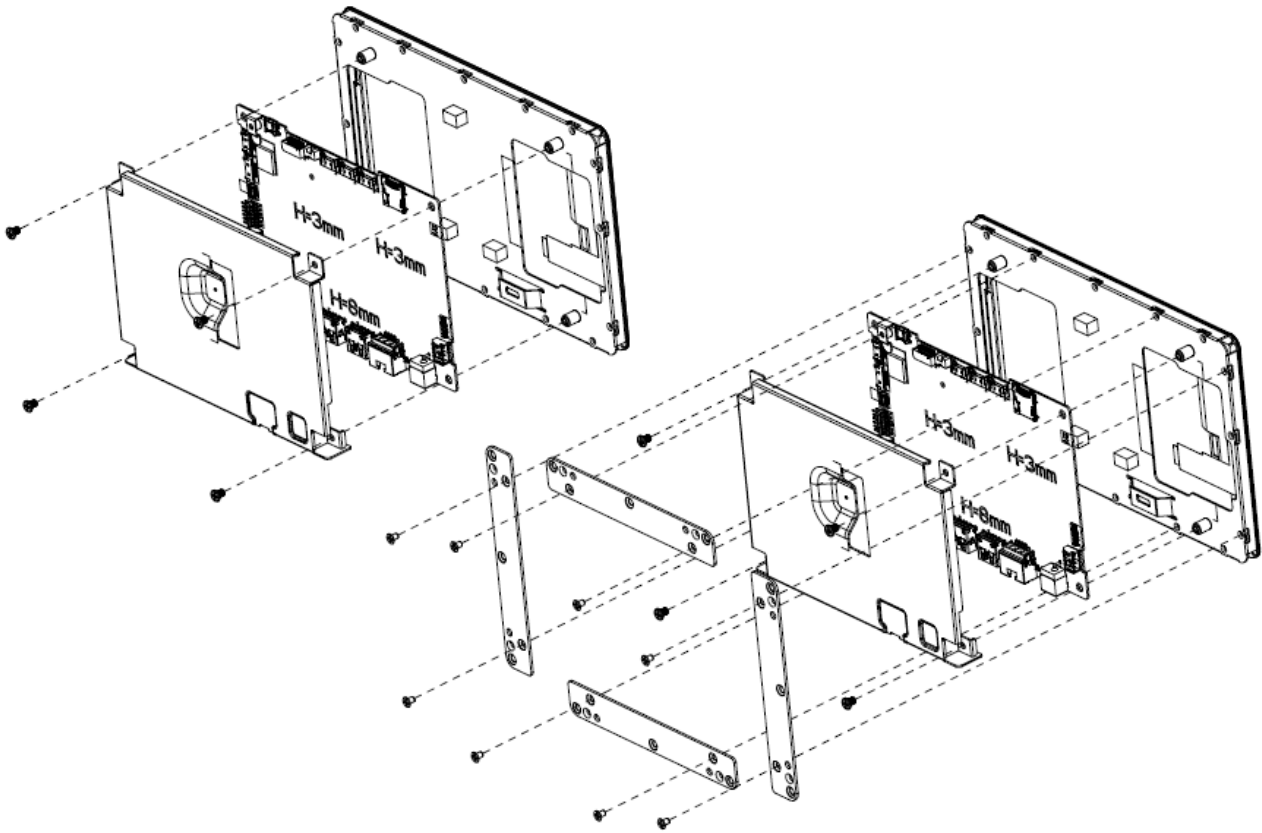

**Step1.** Locate brackets on both sides, matching the holes on the monitor.

**Step2.** Insert and fasten 16 screws on each side of the monitor to secure Mounting brackets.

**Note:** Brackets sold separately.

1.5.3 Front and Rear side (With Extend Bracket)

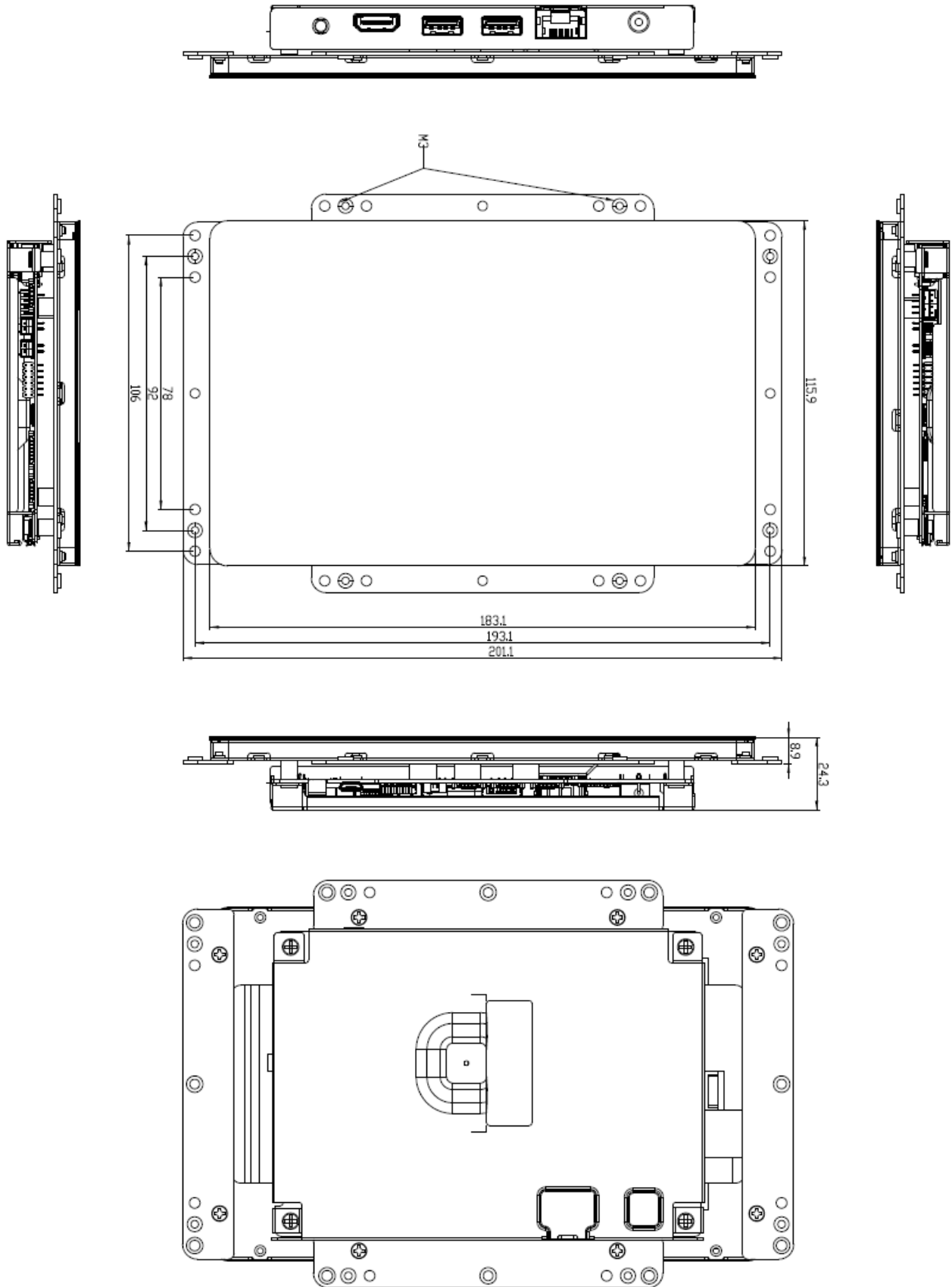

(Unit: mm)

## 1.6 Flush Mounting Concept

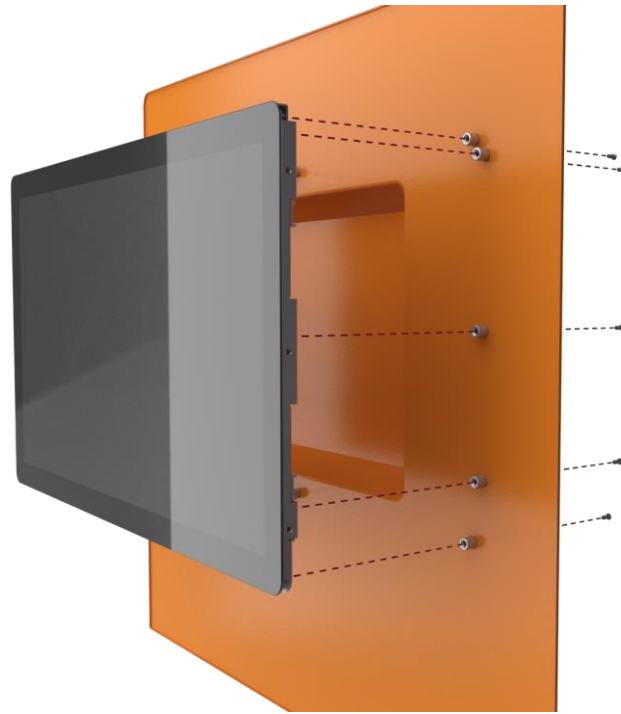

## 1.7 Panel Mounting

### Size of the opening

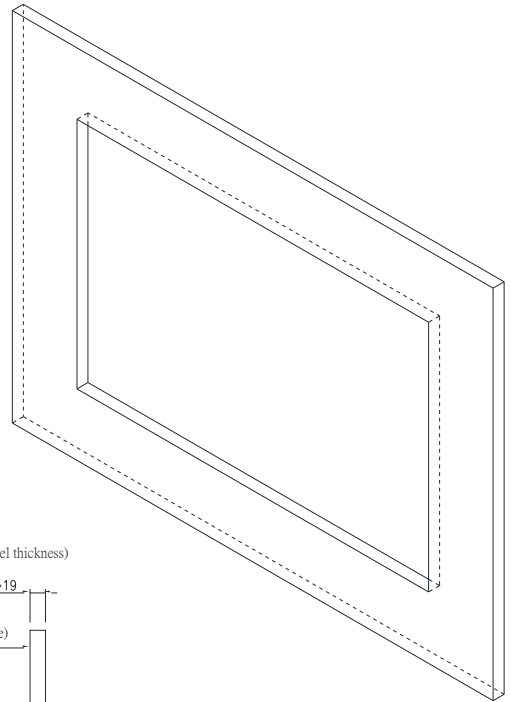
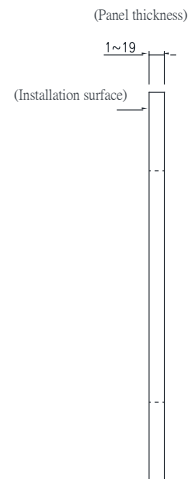
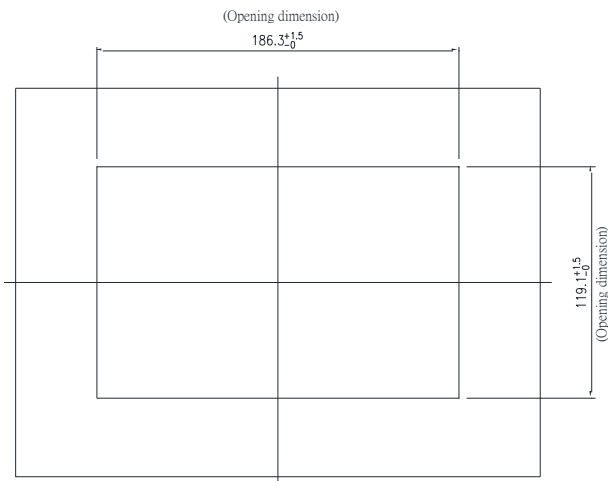

(Unit: mm)

# OFT-07W01

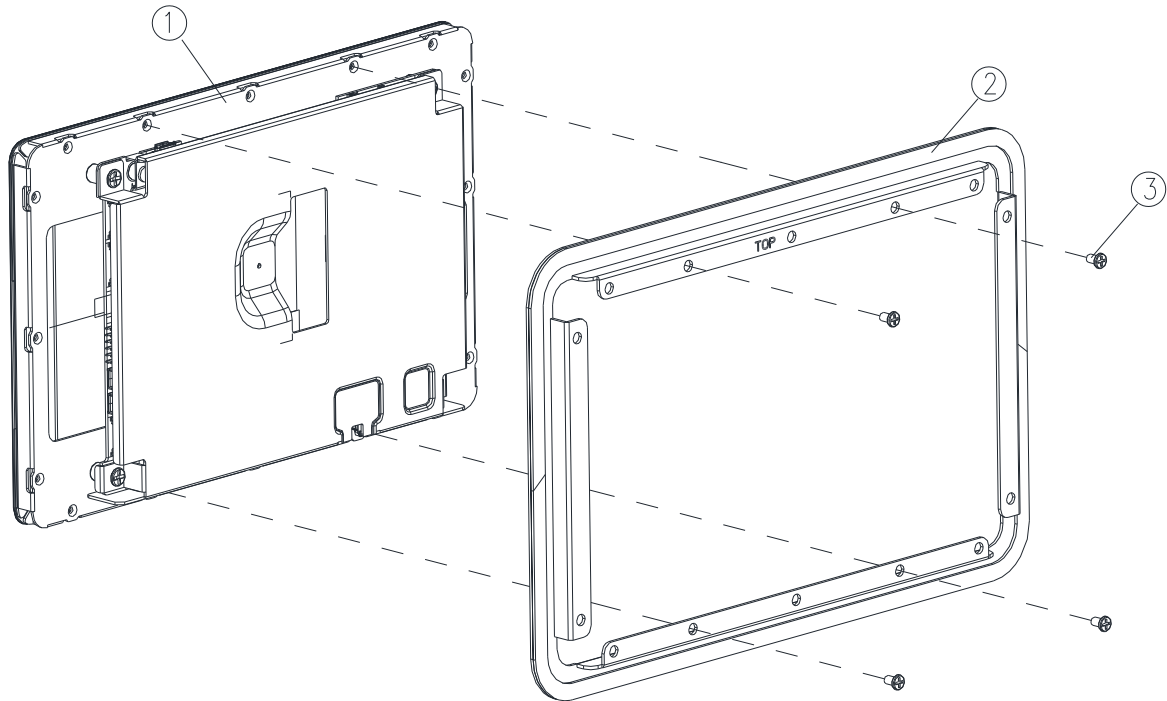

**Step1.** Insert and fasten 4 screws on each side of the monitor to secure Front bracket.

3	Screw	4
2	Front Bracket	1
1	BCX12_07W1_ASSY	1
Item	Part Name	Quantity



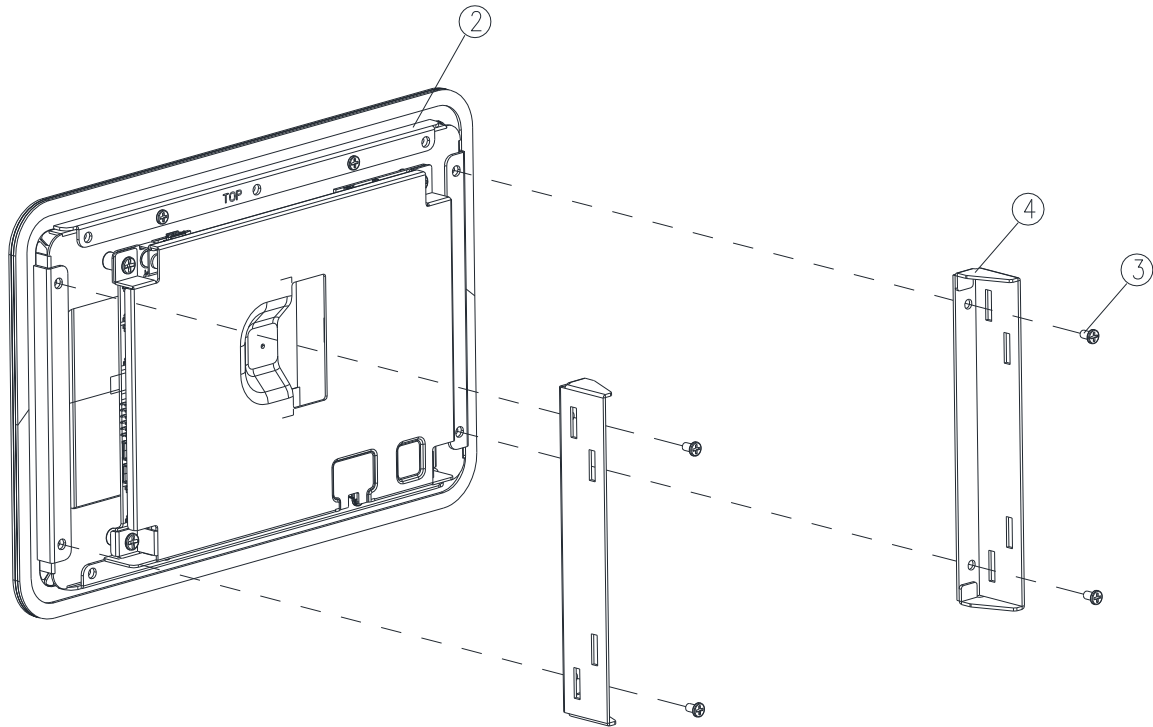

**Step2.** Insert and fasten 4 screws to secure Bracket R/L.

4	Bracket R/L	2
3	Screw	4
2	Front Bracket	1
Item	Part Name	Quantity

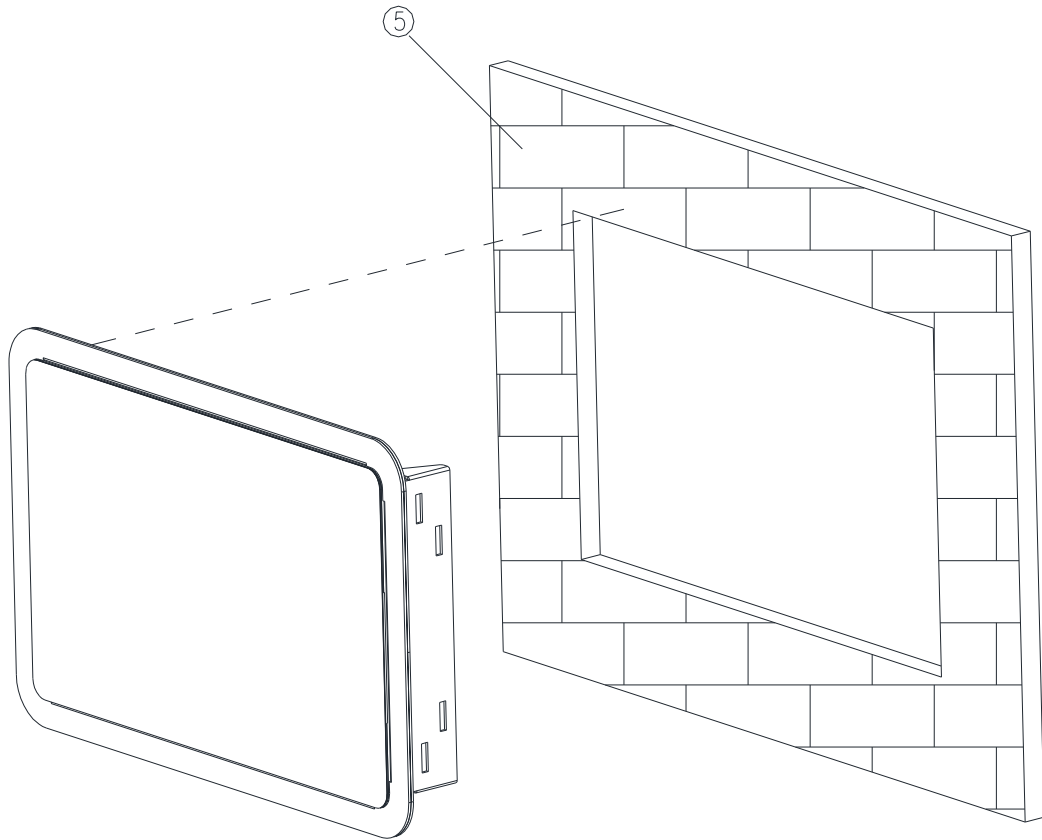

(Outside of the wall)

**Step3.** Insert BCX11 10" Open frame into the wall.

5	Wall	1
Item	Part Name	Quantity

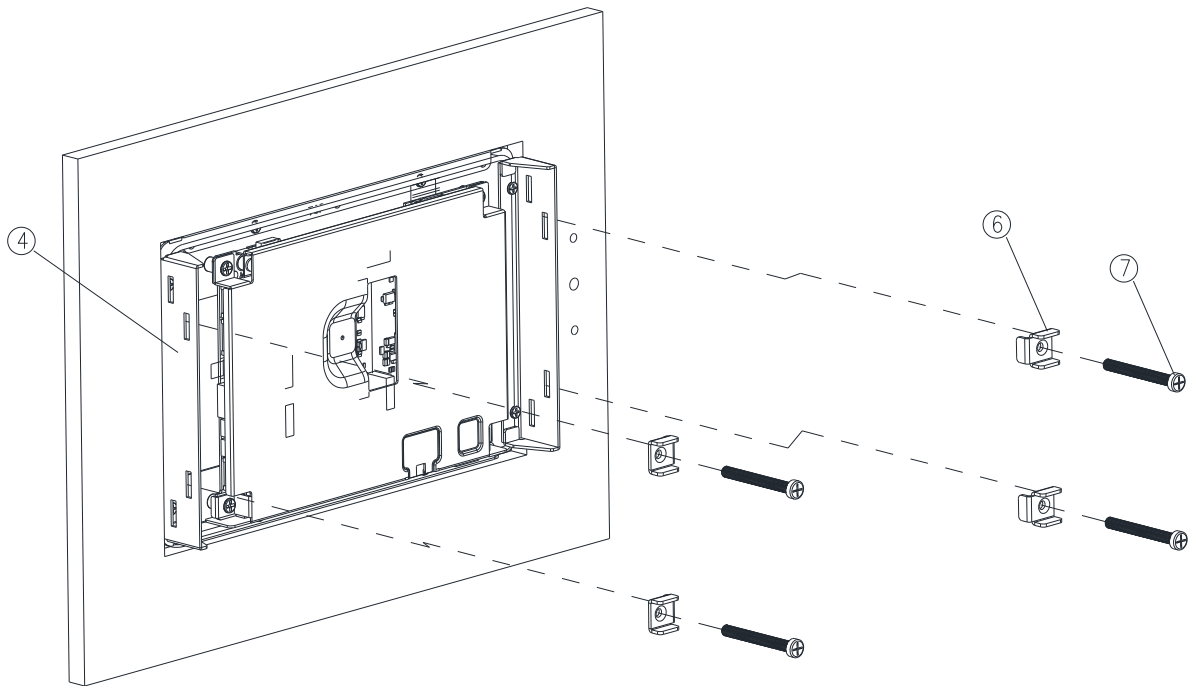

(Inside of the wall)

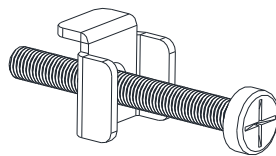

4-1

**Step4.** Fasten 4 screws to secure Panel mount brackets and insert it into Bracket R/L.

7	Panel mount Screw	4
6	Panel mount Bracket	4
4	Bracket R/L	2
Item	Part Name	Quantity

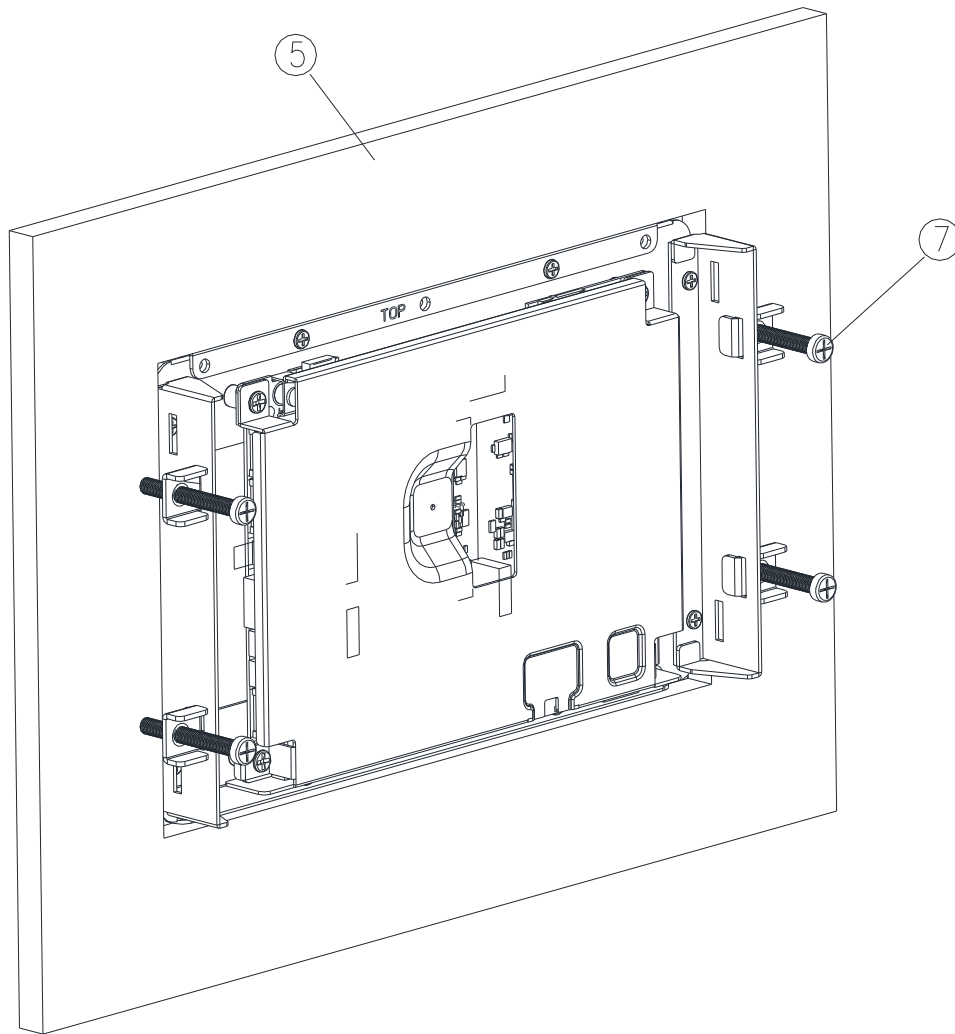

**Step5.** Insert and fasten 4 Panel mount screws to secure the module.

7	Panel mount Screw	4
5	Wall	1
Item	Part Name	Quantity

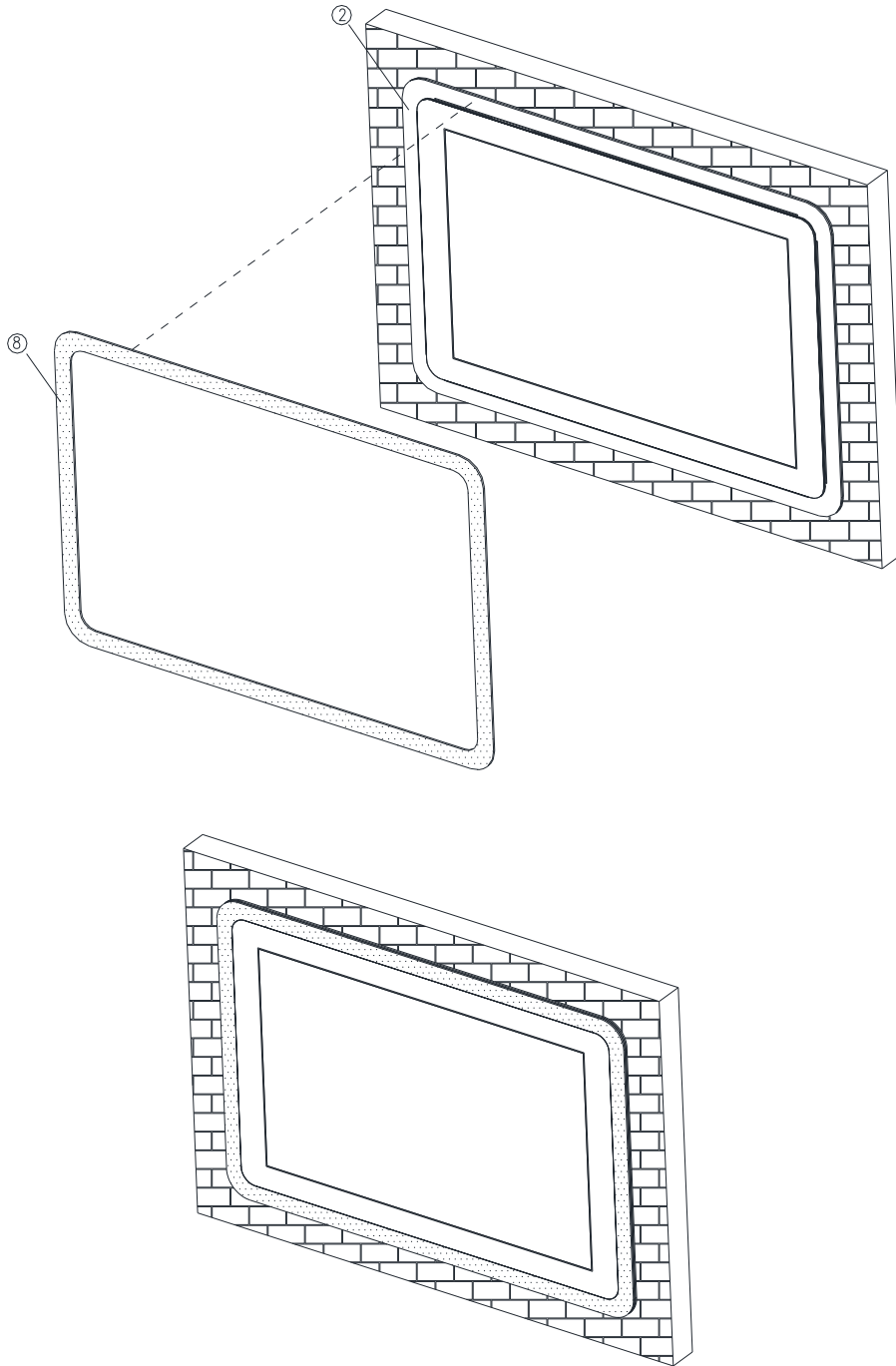

**Step6.** Paste the Decoration Plate on the Front bracket to complete installation.

8	Decoration Plate	1
2	Front Bracket	1
Item	Part Name	Quantity

## 1.8 Wall Mounting Concept

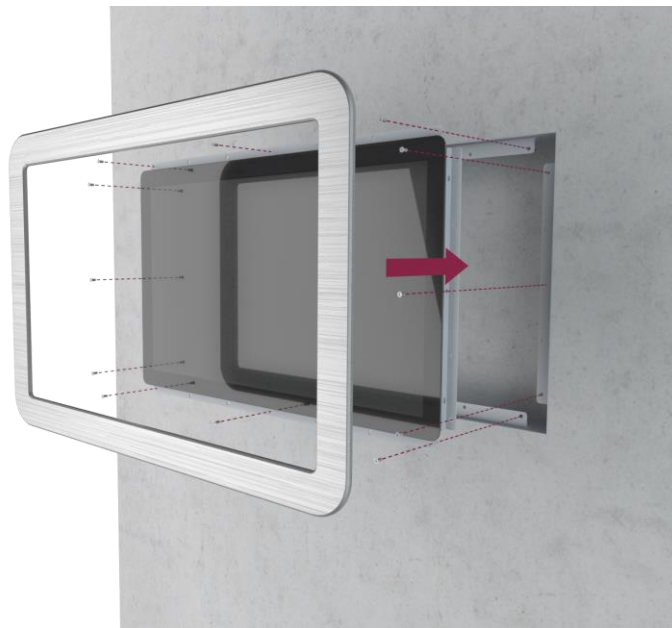
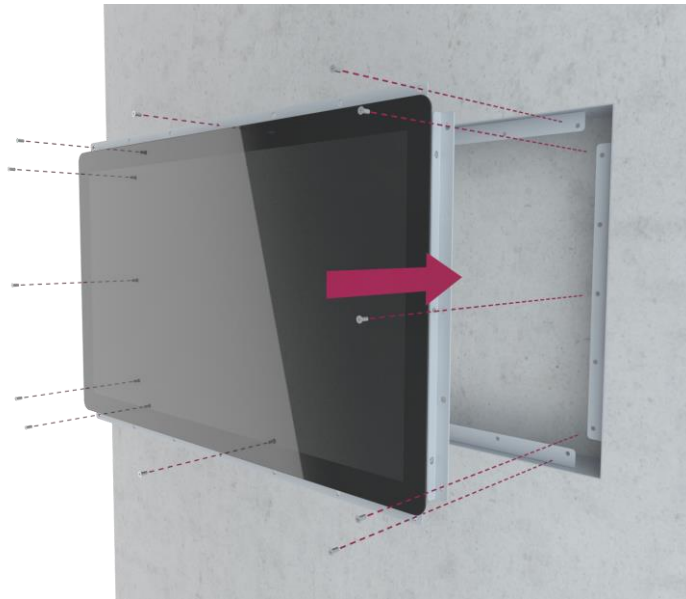

# 2. Hardware Configuration

---

For advanced information, please refer to:

- 1- BCX12 included in this manual.

## 2.1 Architecture Overview—Block Diagram

The following block diagram shows the architecture and main components of BCX12.

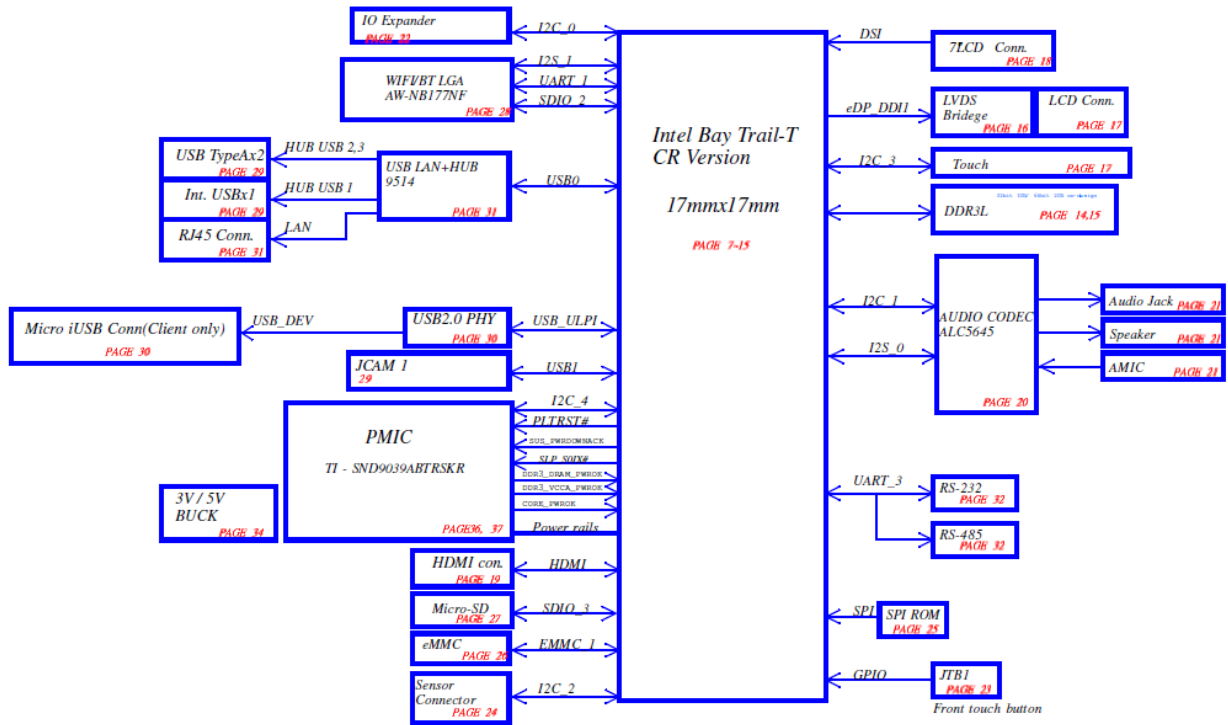



## 2.2 BCX12 Overviews

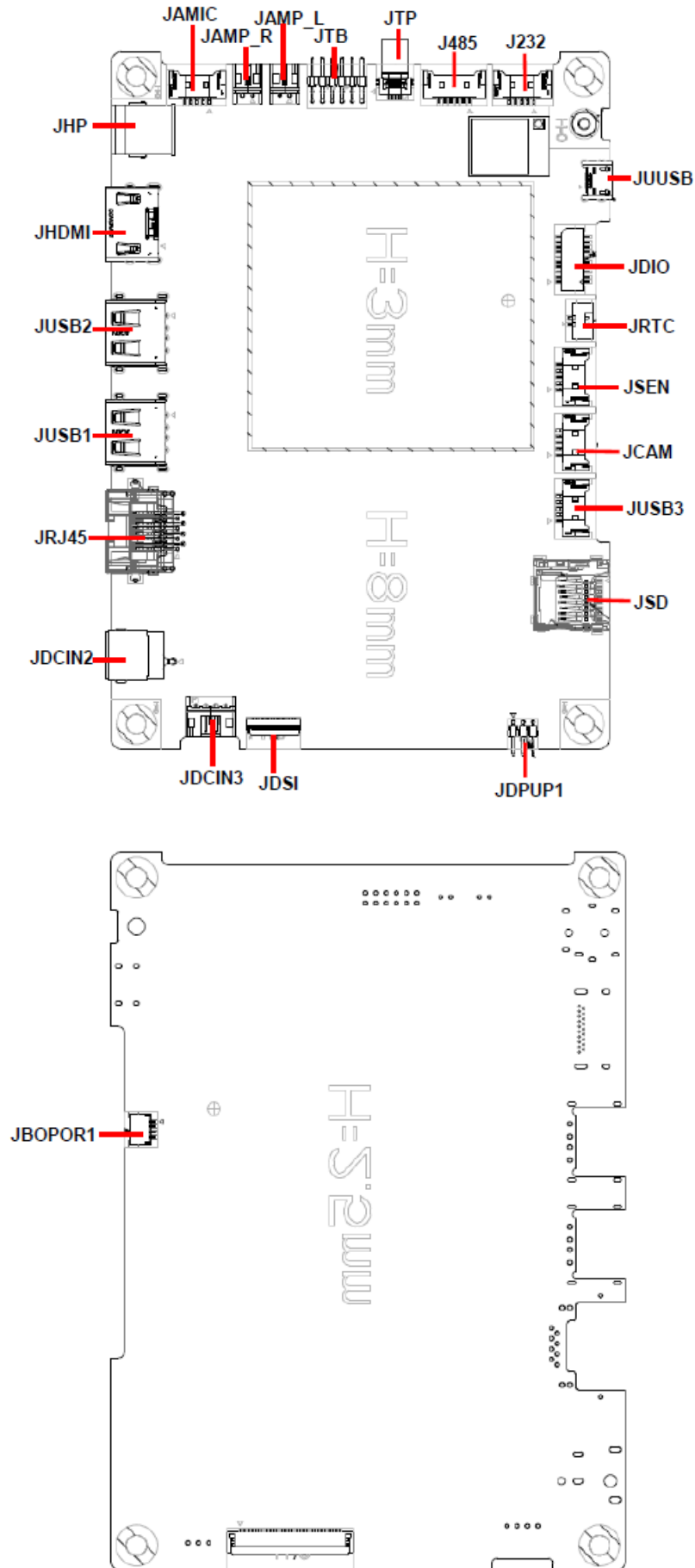

## 2.3 BCX12 Connector list

### Connectors

Label	Function	Note
JHP	Audio line-out connector	
JHDMI	HDMI connector	
JUSB1/2	2 x USB2.0 connector	
JUSB3	USB connector	
JCAM	USB connector	
JRJ45	RJ-45 Ethernet connector	
JDCIN2	DC Power-in connector	
JDCIN3	DC Power-in connector	
JDSI	MIPI FOR 7"	
JTP	Touch connector	
JDPUP1	Debug Port	
JSD	Micro SD card slot	
JRTC	RTC battery connector	
JSEN	I2C connector	
JUUSB	Micro USB connector	
JDIO	General purpose I/O connector	
J485	RS-485 connector	
J232	RS-232 connector	
JAMP_L	SPEAKER_L	
JAMP_R	SPEAKER_R	
JAMIC1	A-MIC connector	
JTB	Touch button board connector	
JBOPOR1	DEBUG connector	

**\*Ethernet LED behavior:**

Label	LED color	Indication	Meaning
<b>Data Rate</b>	Yellow	LED off	10 Mbits/sec data rate is selected
		LED on	100 Mbits/sec data rate is selected
<b>Link/ACT</b>	Green	off	LAN link is not established
		LED on	LAN link is established
		LED Blinking	LAN active is occurring

**\*RTC Battery**

Warning: Risk of Explosion if Battery is replaced by an Incorrect Type. Dispose of Used Batteries According to the Instructions."

Attention: Risque d'explosion si la batterie est remplacée par un type incorrect. Jetez les piles usagées selon les instructions.

## 2.4 BCX12 Connectors settings

### 2.4.1 Touch button board connector (JTB)

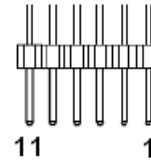
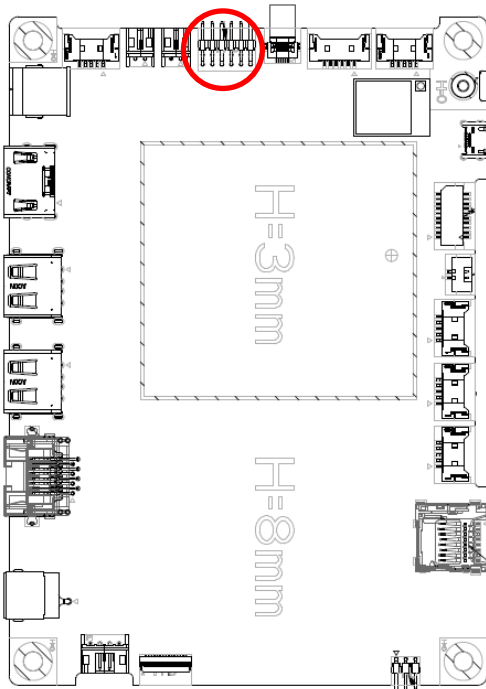

Signal	PIN	PIN	Signal
PWR_JTB1	1	2	GND
NC	3	4	BU1_TV_3V
VOL_UP_3V	5	6	VOL_DOWN_3V
PWRBTN_3V	7	8	BU_BR+_3V
BU_BR-_3V	9	10	BU7_3V
LED_GREEN_con	11	12	LED_ORANGE_con

### 2.4.2 General purpose I/O connector (JDIO)

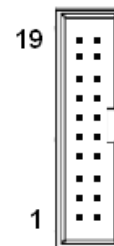
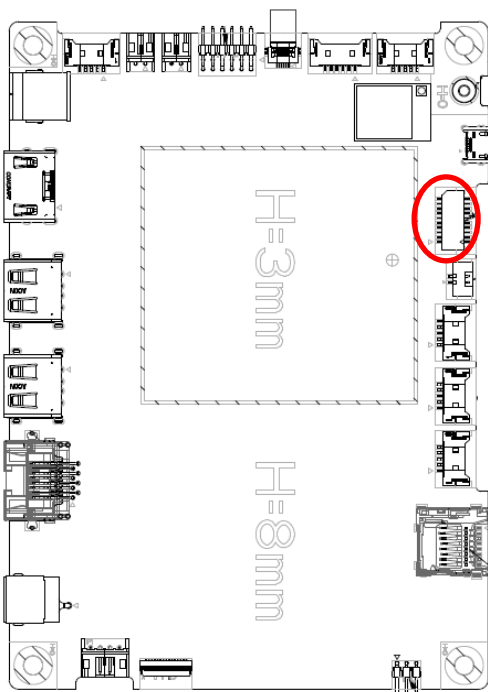

Signal	PIN	PIN	Signal
+5V	19	20	GND
I2C_0_SDA_IO	17	18	I2C_0_SCL_IO
DIO_GP27	15	16	DIO_GP17
DIO_GP26	13	14	DIO_GP16
DIO_GP25	11	12	DIO_GP15
DIO_GP24	9	10	DIO_GP14
DIO_GP23	7	8	DIO_GP13
DIO_GP22	5	6	DIO_GP12
DIO_GP21	3	4	DIO_GP11
DIO_GP20	1	2	DIO_GP10

### 2.4.3 RS-232 connector (J232)

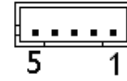
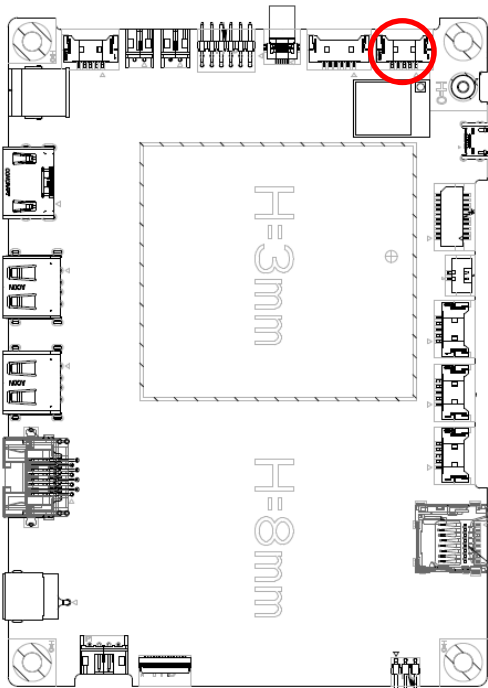

Signal	PIN
DEBUG_TXD	1
DEBUG_RXD	2
NC	3
NC	4
GND	5

### 2.4.4 RS-485 connector (J485)

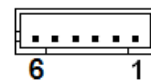
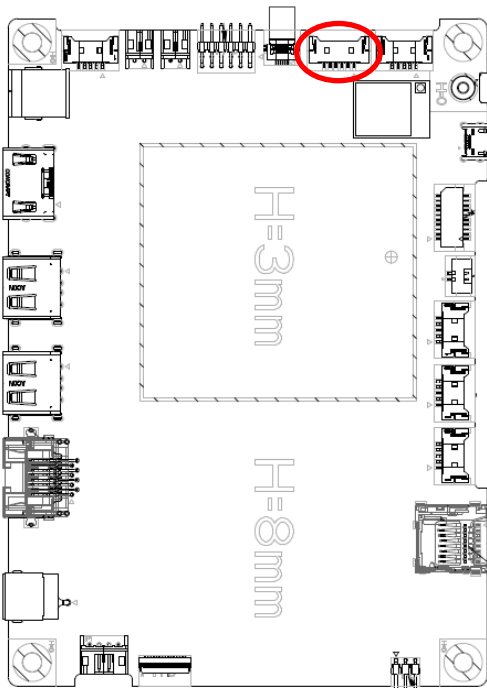

Signal	PIN
485_422TX1-	1
485_422TX1+	2
+5V	3
NC	4
NC	5
GND	6

2.4.5 USB connector (JCAM)

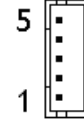
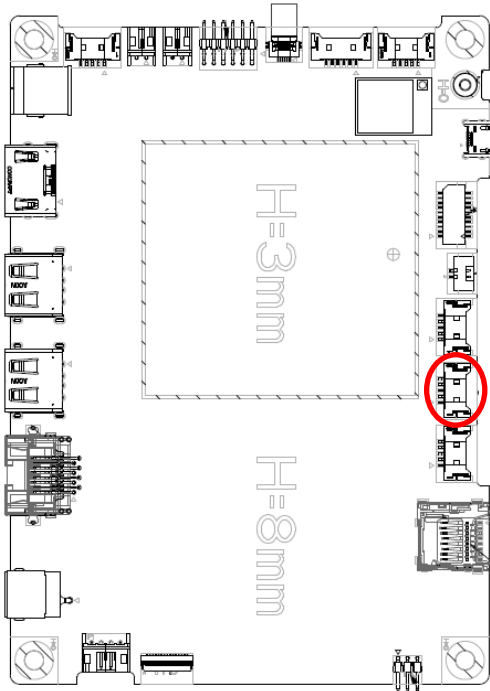

Signal	PIN
GND	5
GND	4
USB20_P1_R	3
USB20_N1_R	2
+5V	1

2.4.6 USB connector (JUSB3)

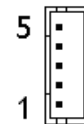
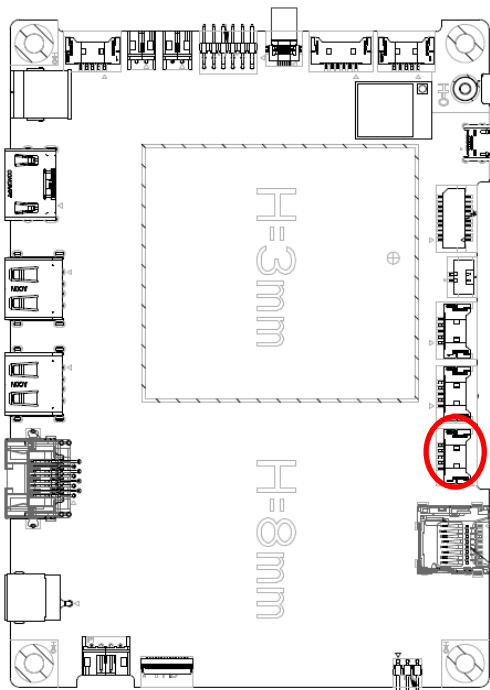

Signal	PIN
GND	5
GND	4
USBDN_9514_P2_R	3
USBDN_9514_N2_R	2
+5V	1

### 2.4.7 SPEAKER\_L (JAMP\_L)

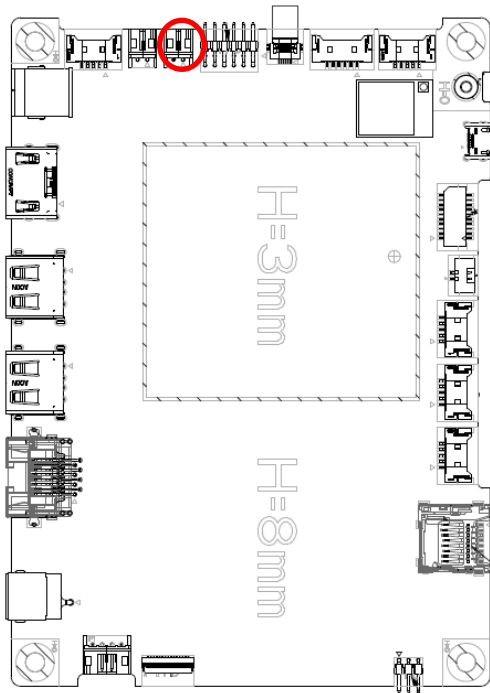

1

Signal	PIN
SPKL_P_R	1
SPKL_M_R	2

### 2.4.8 SPEAKER\_R (JAMP\_R)

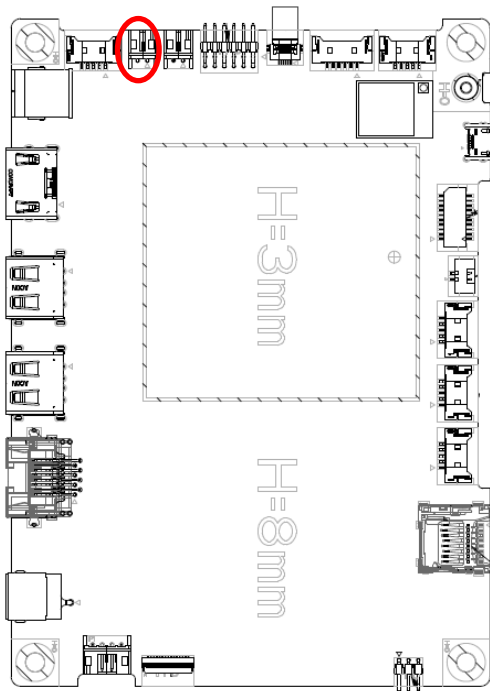

1

Signal	PIN
SPKR_P_R	1
SPKR_M_R	2

2.4.9 A-MIC connector (JAMIC)

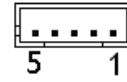
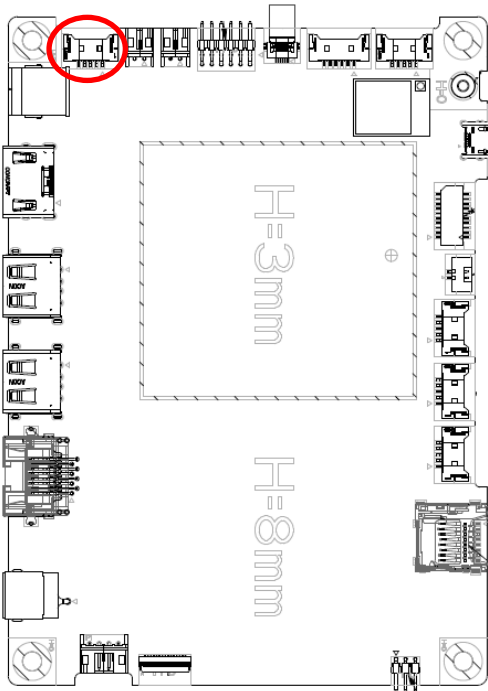

Signal	PIN
NC	1
NC	2
IN2P_C	3
IN2N_C	4
GND	5

2.4.10 I2C connector (JSEN)

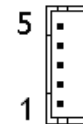
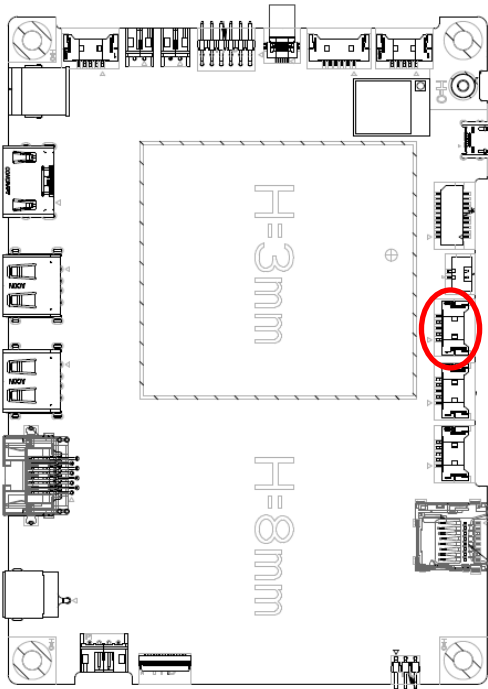

Signal	PIN
GND	5
SENSOR_INT_R	4
I2C_2_SCL_SENSOR	3
I2C_2_SDA_SENSOR	2
+3.3V	1



### 2.4.11 Touch connector (JTP)

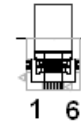
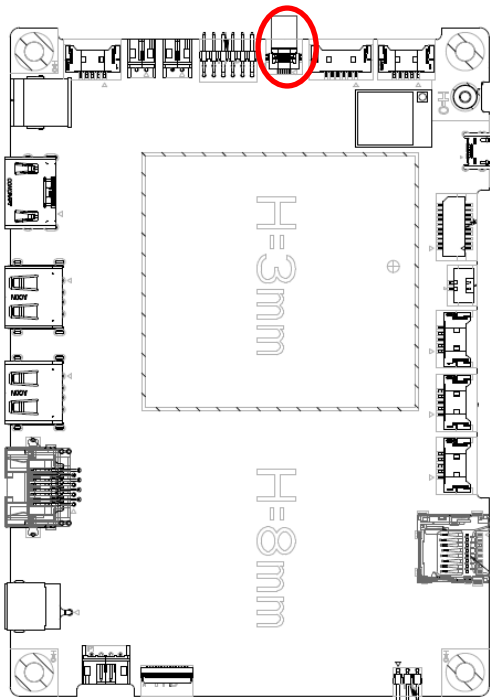

Signal	PIN
+3.3VSB	1
GND	2
TOUCH_INT#_R	3
I2C_3_SCL_R	4
I2C_3_SDA_R	5
TOUCH_RST#_R	6

### 2.4.12 DC Power-in connector (JDCIN3)

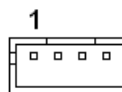
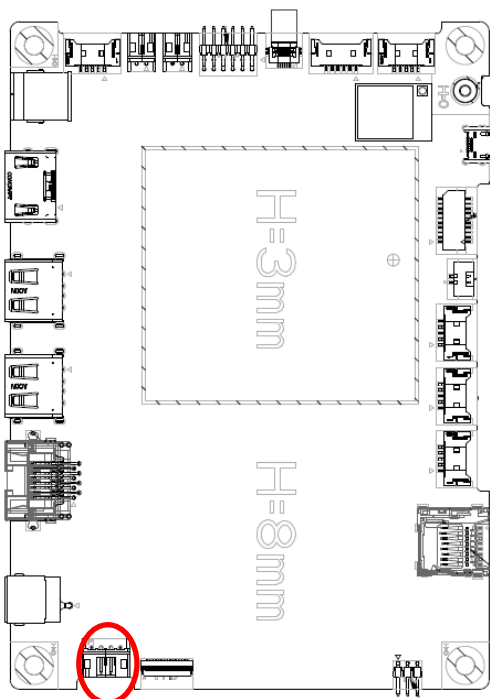

Signal	PIN
+19V	1
+19V	2
GND	3
GND	4

## 2.5 FCC

Contains

FCC ID: TX2-RTL8723BS

IC: 6317A-RTL8723BS

FCC ID is located on the MB WiFi Module:



Remove all screws on shielding cover.



WiFi Module is located on MB underneath of the Shielding cover.



FCC ID is shown on WiFi Module.

## 2.6 Android Rotate Setting

Landscape/portrait mode rotate setting:

Default rotation is 0° → rotate 90°/180°/270° → Power off → Restart

